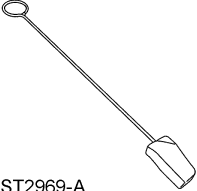

## IN-VEHICLE REPAIR

### Camshaft Phaser and Sprocket

#### Special Tool(s)

|   |   |
|---|---|
|  <p>ST2969-A</p> | <p>Wedge, Timing Chain<br/>303-1175</p> |
|---|---|

#### Removal

1. If servicing the RH camshaft phaser and sprocket, remove the RH camshaft. For additional information, refer to Camshaft — RH in this section.
2. If servicing the LH camshaft phaser and sprocket, remove the LH camshaft. For additional information, refer to Camshaft — LH in this section.

3.  **CAUTION: Damage to the camshaft phaser and sprocket assembly will occur if mishandled or used as a lifting or leveraging device.**

 **CAUTION: Do not remove the Timing Chain Wedge tool at any time during assembly. If the special tool is removed or out of placement, the engine front cover must be removed and the engine must be retimed. For additional information, refer to Timing Drive Components in this section.**

Remove the camshaft phaser and sprocket from the timing chain.

4. Inspect the front of the camshaft phaser and sprocket for missing or damaged roll pins.
  - If the roll pins are missing or damaged, a new camshaft phaser and sprocket must be installed.

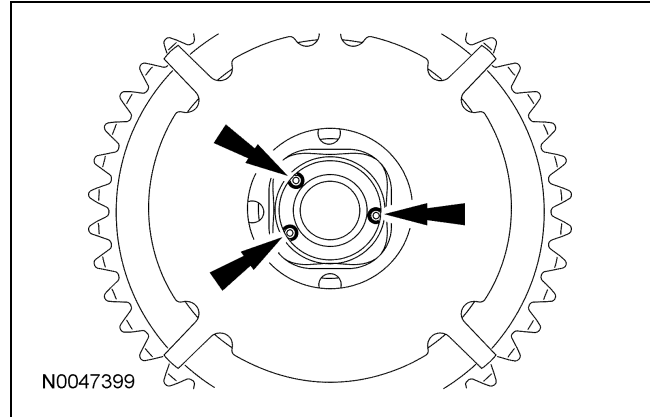

5. Inspect the rear of the camshaft phaser and sprocket for a deformed or damaged location pin.
  - If the location pin is deformed or damaged a new camshaft phaser and sprocket must be installed.

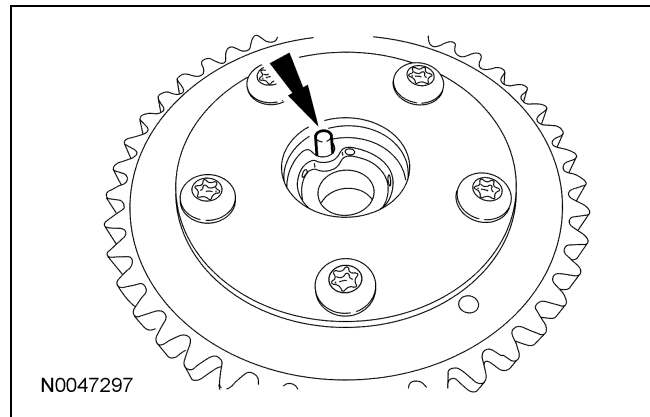

**IN-VEHICLE REPAIR (Continued)**

6. Visually inspect the camshaft phaser and sprocket for squareness (A). If the trigger wheel or spring is deformed or damaged (B), install a new camshaft phaser and sprocket.

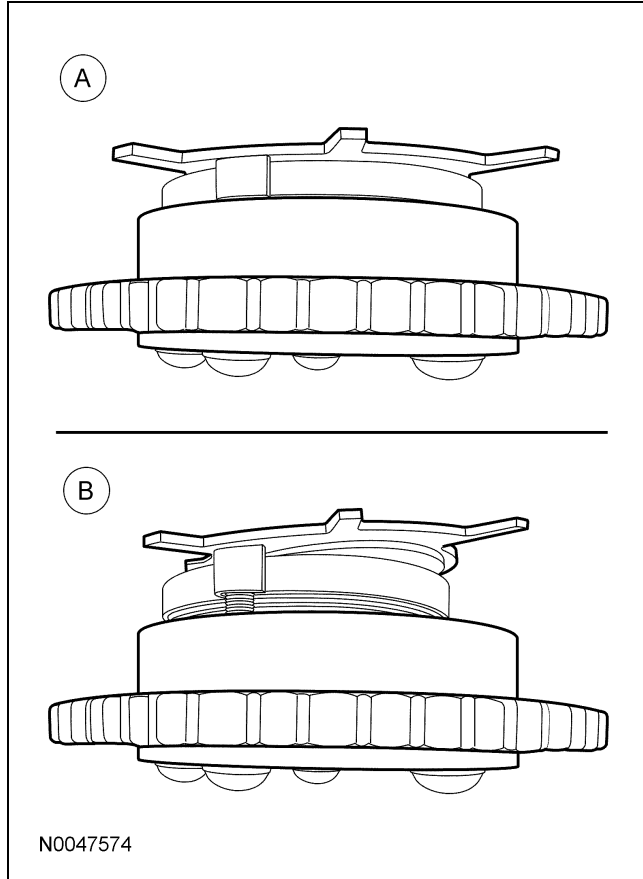
**Installation**

1. **⚠ CAUTION: Damage to the camshaft phaser and sprocket assembly will occur if mishandled or used as a lifting or leveraging device.**

If installing a new camshaft phaser and sprocket, transfer the original scribe mark to the new camshaft phaser and sprocket.

2. **⚠ CAUTION: The timing chain must be installed in its original position onto the camshaft phaser and sprocket using the scribed marks, or damage to valves and pistons will result.**

**⚠ CAUTION: Damage to the camshaft phaser and sprocket assembly will occur if mishandled or used as a lifting or leveraging device.**

Align the scribe marks and position the camshaft phaser and sprocket into the timing chain.

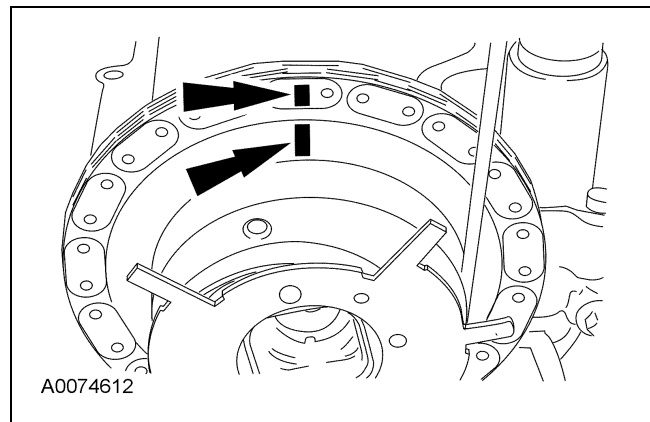

3. If servicing the RH camshaft phaser and sprocket, install the RH camshaft. For additional information, refer to Camshaft — RH in this section.
4. If servicing the LH camshaft phaser and sprocket, install the LH camshaft. For additional information, refer to Camshaft — LH in this section.