

IN-VEHICLE REPAIR

Differential Housing Cover

Material

Item	Specification
SAE 75W-140 High Performance Rear Axle Lubricant XY-75W140-QL	WSP-M2C192-A
Additive Friction Modifier XL-3	EST-M2C118-A
Silicone Gasket and Sealant TA-30	WSE-M4G323-A4

Removal

- With the vehicle in NEUTRAL, position it on a hoist. For additional information, refer to Section 100-02.
- Remove the differential housing cover.
 - Remove the 10 differential housing cover bolts and drain the lubricant from the axle housing.
 - Remove the differential housing cover.

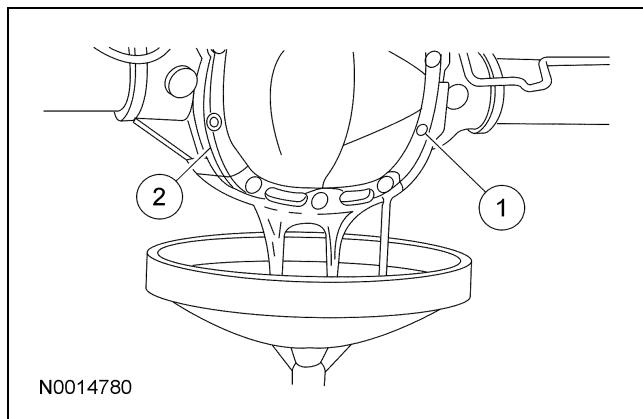

- Apply a new continuous bead of sealant to the differential housing cover.

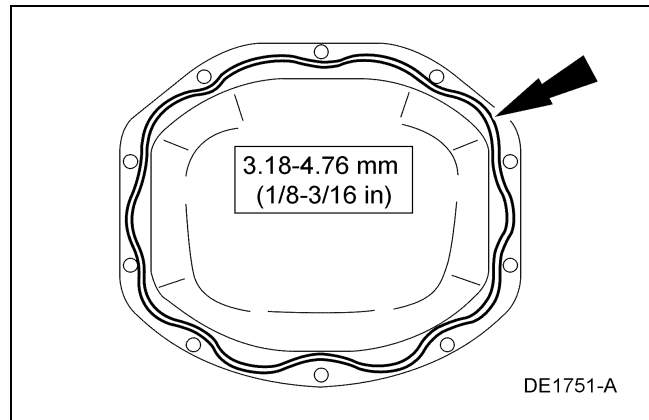

- NOTE:** The differential housing cover must be installed within 15 minutes of application of the silicone sealant, or new sealant must be applied. If possible, allow one hour before filling the axle housing with axle lubricant to make sure the silicone sealant has cured.

Install the differential housing cover and the differential housing cover bolts.

 - Tighten to 45 Nm (33 lb-ft).

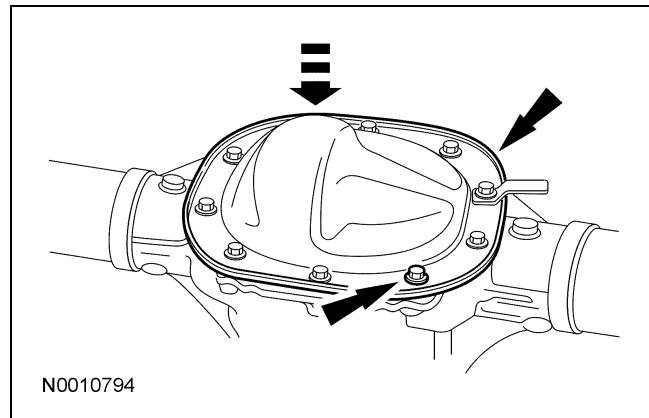

Installation

- CAUTION:** Make sure the machined surfaces on both the axle housing and the differential housing cover are clean and free of oil before installing the new silicone sealant. The inside of the axle housing must be covered when cleaning the machined surface to prevent contamination.

Clean the gasket mating surface of the axle housing and the differential housing cover.

IN-VEHICLE REPAIR (Continued)

4.  **CAUTION:** First fill the limited slip axles with 118 ml (4 oz) of Additive Friction Modifier.

NOTE: Service refill capacities are determined by filling the axle to the level shown.

Fill the axle with 1.50 liters (3.17 pints) of axle lubricant and install the filler plug.

- Tighten to 30 Nm (22 lb-ft).

